

# ProHeat™ 35

## Rolling Induction System

Induction Heating System 

### Quick Specs

#### Applications

Process piping  
Refinery  
Petrochemical  
Power piping  
Pressure vessels

#### Maximum Preheat Temperature

315°C (600°F)

#### Input Power

400–460 V, 3-phase, 50/60 Hz  
460–575 V, 3-phase, 60 Hz

#### Input Amperes at Rated Output

400 V: 60 amps  
460 V: 50 amps  
575 V: 40 amps

#### Rated Output

One rolling inductor: 20 kW at 100% duty cycle  
Two rolling inductors: 35 kW at 100% duty cycle

#### Power Source Dimensions

H: 699 mm (27.5 in.)  
W: 552 mm (21.75 in.)  
D: 933 mm (36.75 in.)

#### Power Source Weight

Net: 103 kg (227 lb.) Ship: 120 kg (265 lb.)



**Powering a heating revolution – for preheat of moving parts up to 315 degrees Celsius (600°F).**

*Specially designed for heating moving parts.*

The ProHeat 35 rolling induction system is a simple and cost-effective heating solution which delivers fast and consistent heat for pipe fabrication shops that weld pipe spools for the refinery, petrochemical, power and HVAC industries.

#### Optimal consistency and quality

- The rolling induction system eliminates the inconsistencies and quality issues associated with open-flame-torch heating methods
- Temperature measurement allows operators to set and achieve targeted preheat temperatures easily with limited button pushing
- The travel detect system prevents hot spots by controlling output based on travel speeds and turning output off if the part is not moving



**ProHeat 35 power source (907690) shown with heavy-duty induction cooler (301298) and optional running gear (195436).**



**Rolling inductor shown with optional mounting arm (301119), travel detect system (301183) and infrared temperature sensor (301149).**

#### Improved safety

- Eliminates open flames, reducing burn as well as fumes and explosive gas hazards
- Direct heat transfer results in cooler shop environment that reduces operator fatigue and improves work conditions

#### Maximum productivity

- Quick time to temperature increases production efficiencies while reducing consumable costs and labor expenses
- Heating while rolling the pipe assembly allows for continuous fabrication
- Compact and portable to configure around various pipe sizes throughout the fabrication shop



#### ITW Welding – BV

Edisonstraat 10  
P.O. Box 1551  
NL-3261 LD Oud-Beijerland,  
Netherlands  
TEL: +31 (0) 186 641 444  
FAX: +31 (0) 186 640 880

#### International Headquarters Miller Electric Mfg. LLC

An Illinois Tool Works Company  
1635 W. Spencer Street  
Appleton, WI 54914 USA  
TEL: +1 920 735 4554  
FAX: +1 920 735 4125  
MillerWelds.com

# ProHeat™ 35 Rolling Induction System

## ProHeat 35 Power Source

**907690** 400–460 V, CE

**907689** 460–575 V

The ProHeat 35 induction power source is equipped with a built-in temperature controller allowing for manual or temperature-based programming with an easy-to-learn operator interface. At more than 90 percent efficiency, the ProHeat 35 power source transfers more energy to the part, reducing operating costs over different heating methods. One ProHeat 35 power source can run a single or double rolling inductor setup. External cooler heat exchanger (300993) recommended when running a double rolling inductor setup.

*Note: Primary input cable not included.*

## ProHeat Rolling Inductor (shown with mounting arm)

**301117** 9.1-meter power cable

**301263** 18.2-meter power cable

Liquid-cooled induction head for use with ProHeat 35, includes thermocouple extension cable and cable cover. The optional mounting arm allows the rolling inductor to ride on the top or side of the pipe.

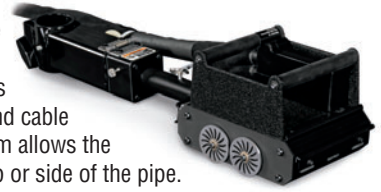

## Running Gear 195436

The running gear adds to the portability of the system. The four 127-millimeter swivel casters with brakes mount to the bottom of the power source or cooler.

## Infrared Sensor Connection Box 301182

Required for connecting the infrared temperature sensor to the ProHeat 35. The connection box allows for two infrared sensors to be connected to one ProHeat. Includes air regulator and filters.

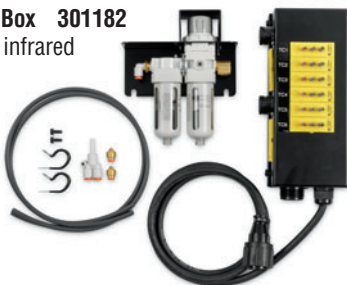

## Heavy-Duty Induction Cooler 301298 (coolant sold separately)

The heavy-duty induction cooler is designed with an efficient fin-and-tube heat exchanger, 9.4-liter rustproof polyethylene tank, high-pressure pump and blower to yield a high cooling capacity. When using two rolling inductors on one system it is recommended to add the external cooler heat exchanger, see Additional Accessories section.

## ProHeat™ 35 Rolling Induction System (Continued)



**Infrared Temperature Sensor 301149**  
Eliminate the need for constant manual monitoring. The infrared temperature sensor can read the temperature of a moving part. Set the desired preheat temperature and the system will quickly heat to that temperature and hold it. The sensor can read from 100 to 400 degrees Celsius (212–750°F). Requires infrared sensor connection box 301182.



**Travel Detect System 301183**  
Avoid overheating — heating rates automatically adjust to varying travel speeds, and when no movement is detected the travel detect system turns off the output preventing damage to the workpiece and rolling inductor. The travel detect system can also be used for setting different heating rates based on workpiece speed of travel. Includes all cabling and mounting hardware.

### Additional Accessories



**External Cooler Heat Exchanger 300993**  
Increases the cooling capacity of the heavy-duty induction cooler. It is recommended when powering two rolling inductors on one ProHeat 35 power source.



**Remote Contactor Control 043932**  
Remotely start and stop the heating process with this wired rocker switch remote. Includes a 7.6-meter (25 ft.) cable.



**RHC-14 Remote Hand Control**  
**242211020** 6 m (20 ft.)  
**242211100** 30.5 m (100 ft.)  
Remotely adjust the heat output of the system in manual mode as well as start and stop the heating process.



**RMS-14 Momentary Switch 187208**  
Momentary-contact switch for contactor control. Rubber-covered dome switch ideal for repetitive on-off applications. Includes a 8-meter (26.5 ft.) cable.

## Specifications (Subject to change without notice.)

### ProHeat 35 Power Source

Input Power	Ambient Temperature Range		Rated Output	IP Rating	Input Amperes at Rated Output	KVA/KW at Rated Output	Dimensions	Weight
	Storage	Usage						
400–460 V, 3-phase, 50/60 Hz, CE	-40 to 55°C (-40 to 131°F)	-15 to 55°C (4 to 131°F)	35 kW at 100% duty cycle	IP23	60 A, 400 V 50 A, 460 V	39/37	H: 699 mm (27.5 in.) W: 552 mm (21.75 in.) D: 933 mm (36.75 in.)	Net: 103 kg (227 lb.) Ship: 120 kg (265 lb.)
460–575 V, 3-phase, 60 Hz					50 A, 460 V 40 A, 575 V			

Certified by Canadian Standards Association to both the Canadian and U.S. Standards. All CE models conform to the applicable parts of the IEC 60974 series of standards.

### ProHeat Rolling Inductor

Rated Output	Ambient Temperature Range		Maximum Part Preheat Temperature	Required Cooler	Dimensions	Shipping Weight
	Storage	Usage				
300 amps at 100% duty cycle	-40 to 82°C (-40 to 180°F)	0 to 60°C (32 to 140°F)	315°C (600°F)	Heavy-duty induction cooler	H: 133 mm (5.25 in.) W: 168 mm (6.6 in.) D: 203 mm (8 in.)	18.1 kg (40 lb.)

# Rolling Inductor Dimensions

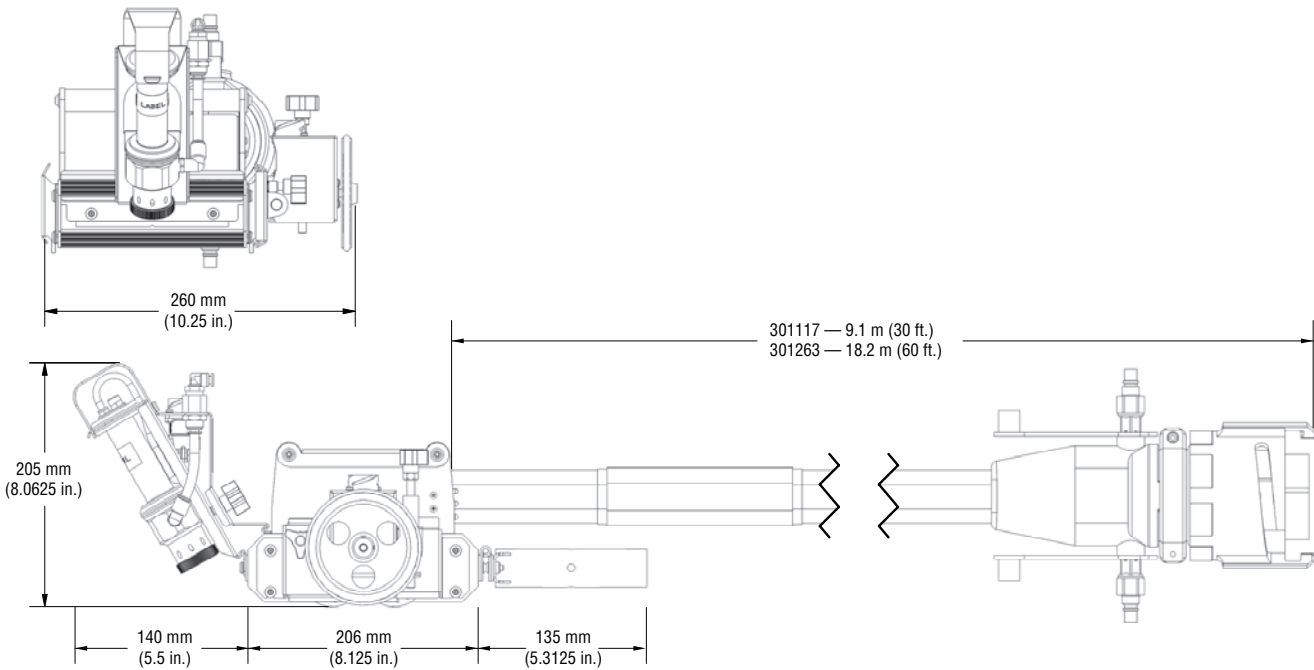

## Ordering Information

Equipment and Options	Stock No.	Description	Qty.	Price
<b>ProHeat™ 35</b>	<b>907690</b>	400–460 V, 3-phase, 50/60 Hz, 35 kW power source, CE		
	<b>907689</b>	460–575 V, 3-phase, 60 Hz, 35 kW power source		
Heavy-Duty Induction Cooler	<b>301298</b>	Cooler only ( <i>coolant sold separately</i> )		
External Cooler Heat Exchanger	<b>300993</b>	Increases the cooling capacity of the cooler, recommended when running two rolling inductors on one power source		
Industrial Coolant	<b>043810</b>	3.78-liter plastic bottle ( <i>must be ordered in quantities of 4</i> )		
Running Gear	<b>195436</b>	Attaches to bottom of power source or cooler		
<b>ProHeat™ Rolling Inductor</b>	<b>301117</b>	9.1 m (30 ft.) liquid-cooled induction head. Includes thermocouple extension cable and cable cover		
	<b>301263</b>	18.2 m (60 ft.) liquid-cooled induction head. Includes thermocouple extension cable and cable cover		
Infrared Temperature Sensor	<b>301149</b>	Attaches to the rolling inductor. Measures the temperature of moving parts from 100–400°C (212–750°F). Requires infrared sensor connection box 301182		
Infrared Sensor Connection Box	<b>301182</b>	Attaches to the power source. Allows for the connection of two infrared temperature sensors		
Travel Detect System	<b>301183</b>	Attaches to the rolling inductor. Comes with cabling and mounting hardware		
Mounting Arm	<b>301119</b>	Attaches to the rolling inductor for mounting to pipe stand		
Remote Contactor Control	<b>043932</b>	7.6 m (25 ft.) wired remote on/off for power source		
RHC-14 Remote Hand Control	<b>242211020</b>	6 m (20 ft.) wired remote for heat and on/off for power source		
	<b>242211100</b>	30.5 m (100 ft.) wired remote for heat and on/off for power source		
RMS-14	<b>182208</b>	8 m (26.5 ft.) momentary contactor switch for repetitive on-off applications		

Date:

Total Quoted Price:

Distributed by:

